

Arc Flash Energy Calculation Methods and Challenges for Microgrids

James M. Onsager
Senior Engineer
S&C Electric Company
Franklin, WI
James.Onsager@sandc.com

Michael J. Higginson
Senior Engineer
S&C Electric Company
Chicago, IL
Michael.Higginson@sandc.com

Abstract— Arc flash hazards must be considered to work safely on any electrical system. Microgrids can contain several types of electrical systems working together. These systems commonly include medium and low voltage AC, DC energy storage, and DC photovoltaic (PV) electrical systems. Because the arc behavior and considerations vary from system to system, each of these types of electrical systems can require different methods of estimating the possible arc flash incident energy released during an event. Microgrids also present several challenges in performing arc-flash incident energy calculations, including significantly varying short-circuit current levels across grid-tied and islanded operation, bi-directional fault current flow, and protection complexity. These challenges in microgrids can require special attention when analyzing arc flash incident energy levels and associated arc flash hazards.

This paper provides an overview of the types of electrical systems and sources found in a typical microgrid; what methods can be used to calculate incident energy in each system. A novel approach of calculating the Arc Flash energy for multiple time-varying AC sources of fault current can be considered in an arc flash calculation by doing a piecewise integration. For the calculation, a single source can be represented by several resources if their contribution is time-varying. Although this approach has been applied to many recent analytical studies performed by authors, further verification through analyses is recommended.

Index Terms—Arc Flash, BESS, Energy Storage, Microgrids, Photovoltaic, PV, Protection, Safety

I. INTRODUCTION

All types of electrical systems operating >50 Volts are recommended to be analyzed for arc flash hazards per NFPA 70E Electrical Safety in the Workplace [1]. This includes microgrids. A microgrid is a group of interconnected loads and distributed energy resources (DERs) within clearly defined electrical boundaries that acts as a single controllable entity with respect to the grid [2]. If designed to do so, a microgrid

can connect and disconnect from the grid to enable it to operate in either a grid-connected mode or a standalone/islanded mode.

An example one-line of microgrid with multiple types of DERs can be found in Figure 1.

To determine the severity of an arc-flash hazard an incident energy analysis is conducted. Incident energy is defined by NFPA 70E [1] and IEEE Std. 1584 [3] as “the amount of thermal energy impressed on a surface, a certain distance from the source, generated during an electrical arc event. Incident energy is typically expressed in calories per square centimeter (cal/cm^2).” Arc-flash incident energy levels at specific equipment and working conditions vary primarily based upon two components; fault current, which is system topology/configuration dependent, and clearing time, which depends on the design of the protection scheme. Arc flash incident energy levels are typically highest when the fault currents are the greatest in magnitude and/or when time durations are the longest. When time-overcurrent protection schemes protect system components from arcing faults, the incident energy levels may be higher at lower fault current levels due to a longer clearing time of the protective devices at lower current.

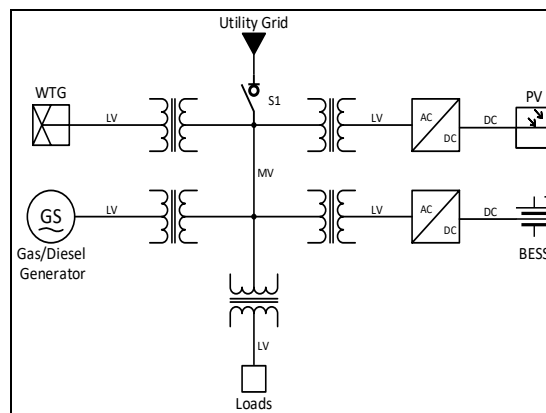

Figure 1. Sample Microgrid One-Line Diagram

The combination of DERs in a microgrid can complicate the incident energy analysis of the system. For example, some DERs have DC systems (e.g. solar photovoltaic) and require different calculation methods than AC systems. Additionally, AC systems must account for different types of DERs producing low levels of fault current for various durations of time. Various fault current scenarios should be considered, including when the system is grid-connected and when it is running in islanded mode, as well as the effect of multidirectional current flow during the arcing fault.

II. DC SYSTEMS

A. Battery Energy Storage Systems

Microgrids often contain battery energy storage systems (BESS). These systems are typically connected to the rest of the microgrid through bi-directional DC to AC inverters and range in size between one hundred kilowatts to several megawatts. The battery DC voltage can be 500-1,000 VDC or higher. A BESS can contain large quantities of batteries that are charged and discharged as needed to manage energy in the microgrid. Batteries that are commonly used include chemistries such as lithium-ion (Li-ion), sodium sulfur (NaS), sodium-nickel chloride (NaNiCl₂) and lead acid. These battery systems often consist of series-connected batteries, to achieve the desired DC voltage. The series connections of batteries are then connected in parallel to achieve the desired storage capacity.

When analyzing the DC side of a BESS system to calculate the incident energy levels in the event of an arcing fault, there are several methods available. Some of those methods include detailed modeling of the DC arc as suggested in a paper by Ammerman et. al. [4]. Alternatively, one of the most common methods used to calculate incident energy from a battery source is known as the Maximum Power Method which was originated by D. Doan [5] and also included in NFPA 70E [6]. This method is simple to calculate, but it is also considered to produce a conservative result because it is based on maximum power transfer into the arc, resulting in the highest possible arc power and incident energy. An additional multiplier is used when the arc occurs in an enclosure to consider the amplification effect of the enclosure towards a person (e.g. the shape of the enclosure can focus the arc heat energy out towards the operator). Prior to the 2018 version of NFPA 70E [1], the recommended multiplier was three (3). However, in the 2018 version the wording was changed to “Research with ac arc flash has shown a multiplier of as much as 3× for arc-in-a-box [508 mm (20 in.) cube] versus open air. Engineering judgment is necessary when reviewing the specific conditions of the equipment and task to be performed, including the dimensions of the enclosure and the working distance involved.” Alternative multipliers to account for the effect of enclosures on incident energy levels are presented in a paper by M.D. Fontaine and P. Walsh [7] and consider the size of the enclosures as well as the distance of the worker to the arc to determine the multiplication factor.

Working with batteries is considered energized work since they are not able to be put into an “Electrically Safe Work Condition” per NFPA 70E [1] due to the inability to de-energize a battery. Thus, assembly and disassembly of the series battery

string is a scenario that should be considered. As a string of series connected batteries is assembled, the available fault current remains the same, but the voltage increases as each cell or module is added, resulting in increasing incident energy and shock hazard voltage. The design of some commercially available BESS battery modules contains an internal fuse, as shown in Figure 2, that offers protection from external short circuits and can greatly reduce the duration of arcing fault and in turn the available incident energy. When analyzing the BESS system for incident energy, the location of overcurrent protective devices (OCPD) and the layout of the modules and equipment can significantly affect the available incident energy.

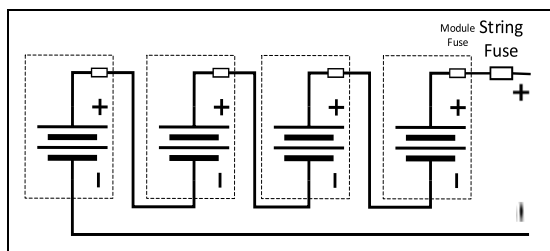

Figure 2. BESS Battery String Example with Fuse Locations

Regardless of OCPD locations in the BESS battery system, the maximum available fault current is typically at 100% state of charge (SOC) of the battery at the time of the arcing fault. However, a battery may not be at 100% SOC at the time of an arcing fault and therefore could produce lower fault current. This lower current may lead to a longer clearing time of over current protection and therefore higher incident energy. Battery fault currents and various SOC should be available from the battery manufacturer. If actual fault current is not available at lower SOC, a paper by K. Carr [8] provides suggested current reduction factors that can be applied and also considers the age of the batteries.

B. Control Power Battery Systems

DC control power systems with battery backup are also common in microgrids. These systems are useful to ensure that control and protection systems can operate to initiate a microgrid island if the bulk system connection is lost. Compared to the power reserves of a BESS, they are much smaller, and the voltage is often 125 VDC or lower. The same methods listed in the previous section for analyzing a BESS can be applied on DC control power or other similar systems.

C. Photovoltaic Systems

Microgrids frequently are designed with renewable generation, such as solar photovoltaic (PV), to supplement other forms of generation. Solar PV systems are connected to the AC grid through a DC to AC inverter and ranges in size from kilowatts to megawatts. Like batteries, the output of PV modules is DC. Unlike batteries, PV cells' relationship between voltage and current are non-linear where the current output acts as a current source that varies with DC system voltage. For this reason, the incident energy calculation methods described in previous sections do not apply and will provide unreasonably low incident energy levels if used. An example PV module IV curve can be seen in Figure 3. PV output power delivered depends upon the

product of voltage and current or is equal to the square of the current multiplied by the arc resistance (assuming all PV output power goes into the arc). If arc resistance is very low, the voltage will be low and in turn the power is low. However, if it happens that the arc resistance is of a value to cause operation near the maximum power point, the voltage will be high and the power into the arc may be equal to the rated power of the DC system. This method of calculating incident energy in PV systems is explained in a technical article by Enrique [9]. An additional multiplier can be used when the arc occurs in an enclosure. M.D. Fontaine and P. Walsh [7] considered the size of the enclosure and the distance of the worker to the arc to determine the multiplication factor.

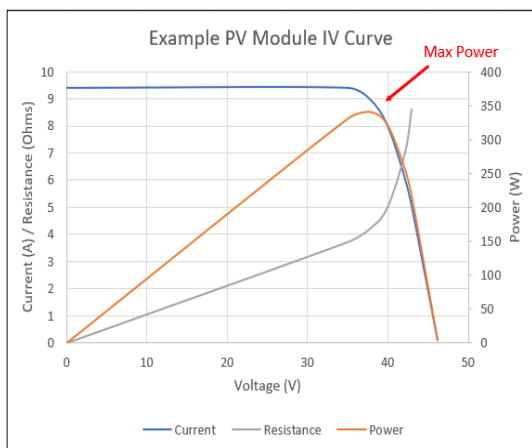

Figure 3. Example PV Module IV Curve

The above methods produce a conservative incident energy result, assuming that the arc voltage is the same as the maximum power point. While this may not be likely to occur, however this method produces a worst-case scenario that can be used with confidence that the actual incident energy is less. Testing on PV systems to determine actual arc voltages have been conducted (and are ongoing). This testing shows that the actual arc voltage can be much lower, resulting in lower available incident energy. However, more testing is needed before setting on a standard set of equations will be developed [10].

III. AC SYSTEMS

Microgrids commonly utilize an AC power distribution backbone. This distribution system commonly includes low voltage (LV) and medium voltage (MV) equipment, connecting the distributed energy resources (DERs) and local loads. Local DERs can include diesel and gas generators, wind turbine generators (WTGs), BESS and PV. Performing arc flash incident energy analysis on a microgrid's AC components requires unique considerations. Some of these considerations are described below.

A. Arc Flash Incident Energy Analysis of Microgrid Components at Different Voltage Levels

Microgrids often include both low-voltage and medium-voltage components. Calculating arc flash incident energy levels at different voltages requires the use of different techniques. OSHA indicates which methods are reasonable incident energy

calculation methods in Table 3 of [11]. Microgrids with both low-voltage and medium-voltage equipment may require the use of different calculation methods for different voltage components.

Arc flash incident energy levels for AC systems operating at or below 15 kV can be calculated using the empirical equations provided by IEEE Std 1584-2018 [3]. These equations were developed based on the results of extensive testing. They consider various parameters that can affect the available incident energy including fault current levels, clearing time, arc gap length, electrode orientation, and enclosure size. This calculation method is commonly incorporated in commercially available power system analysis software for ease of use.

AC systems that are operating above 15 kV are outside the tested range for the empirical equations from IEEE Std 1584-2018. Some power system analysis software tools will use the "Lee Method" for equipment above 15 kV. The Lee Method is a theoretical incident energy calculation method from a paper by Lee [12]. This method produces a very conservative incident energy level estimate. Furthermore, the Lee method does not account for an arc occurring within an enclosure. Alternate physics-based calculation methods are available to calculate incident energy for arcs in systems above 15 kV such as ARCPRO, Duke HFC, EPRI and Terzija/K as analyzed in a paper by Marroquin et. al. [13]. OSHA lists ARCPRO as producing a reasonable incident energy level calculation method for equipment above 15 kV as well as allows for any other method that produces a reasonable result [11].

B. Microgrid System Fault Current Levels

Microgrid systems also have significantly different fault current characteristics than typical systems. Microgrid systems can have significantly different fault current levels during grid-tied when compared to islanded mode of operation. Furthermore, microgrids have DERs contributing bi-directional fault current during an arc flash event, and fault current may vary as a function of time during a fault.

Microgrids are capable of operating grid-tied, where it is interconnected with the bulk system, and islanded, where the microgrid is disconnected from the bulk system. The bulk system typically supplies significantly more fault current than local DERs. Rotating machines typically supply six per-unit current or less, and inverter-based devices typically supply two to three per-unit current. Thus, when the microgrid is operating islanded, the fault current levels can be much lower than when operating grid-tied. These different modes of operation can lead to significantly differing fault current levels, which may consequently result in significantly different arc flash incident energy levels. IEEE 1584-2018 recommends that maximum and minimum fault current levels are considered to ensure worst-case scenarios are considered [3]. In microgrids, additional intermediate fault current levels (e.g. with different DER dispatch permutations) may also need to be evaluated to ensure worst-case scenarios are considered.

In addition to significant differences in fault current levels between grid-tied and islanded operation, microgrid fault current itself has different characteristics than a typical electrical

power distribution systems. The use of DERs in microgrids will result in fault contributions from multiple sources. As seen in Figure 1, a fault anywhere in the AC system will result in fault contributions from multiple DERs and possibly the utility, if grid connected. Consequently, faults will require operation of multiple protective devices to clear all sources of fault current. Furthermore, DER fault current may change as a function of time. For example, rotating machines typically have a time-dependent decrement curves, which cause fault current levels to change as a function of time. Figure 4 shows an example of fault current variation as a function of time from an example generator, based on data from generators applied by the authors in past projects.

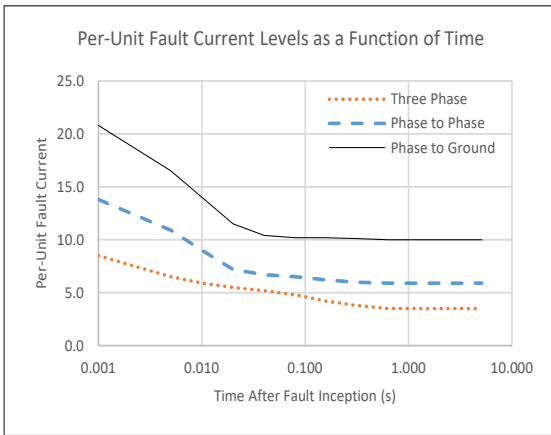

Figure 4: Generator Fault Current Decrement

Inverter-based DERs' short circuit output is affected by the controls and internal protection utilized at the time of the fault. Two common controls commonly used are voltage control and current control. Most commercially available inverters operate in current control mode. In this mode the DER responds to a fault by producing a short spike of current (as short as 1 ms) from inverter filter capacitor discharging, then returns to a current output of one per-unit and continues to feed the fault. An example waveform of the output of an inverter-based DER in current control mode can be found in Figure 5 [14]. BESS and PV inverters both commonly operate in current control mode, especially when the microgrid is operating grid-connected.

When a microgrid is operating in islanded mode it needs some resources operating as a voltage and frequency reference to function as a slack bus and for other DERs to follow. Some BESS inverters can provide this functionality. When the inverter is operating in voltage source mode it responds differently to a fault than when in current control mode. As can be seen in Figure 6 [14], with the voltage held constant the current output increases to feed the fault. This increased current is typically limited to a maximum of 2-3 per-unit of the inverter ratings. If the impedance of the fault is low enough that is current is above the inverter internal protection thresholds, the inverter will either curtail the fault current after a few cycles [14] or continue operation at its maximum current output and limited voltage.

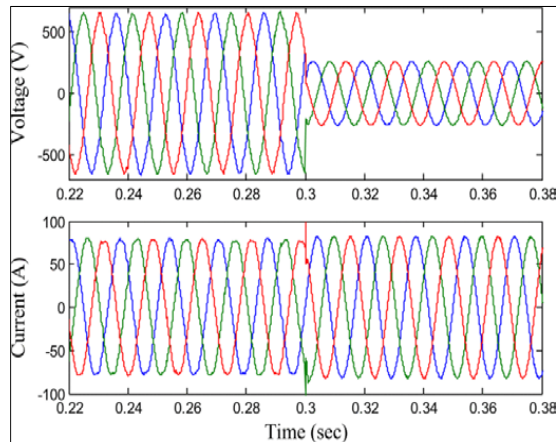

Figure 5. Inverter based DER under current control mode: (top) output voltage and (bottom) output current for a short-circuit fault at $t=0.3$ s. [14] (©2014 IEEE)

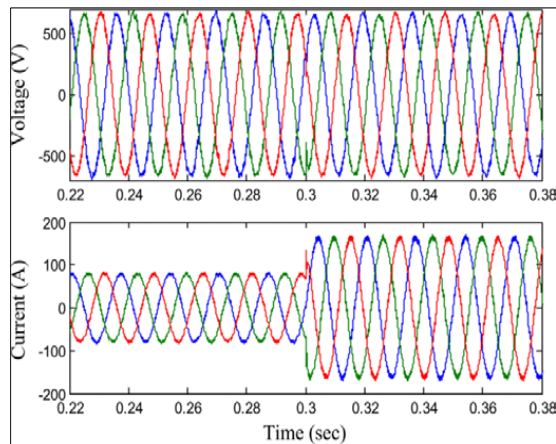

Figure 6. Inverter based DER under voltage control mode: (top) output voltage and (bottom) output current for a short-circuit fault at $t=0.3$ s. [14] (©2014 IEEE)

Because of the reduced fault current levels while islanded and bi-directional fault current flow, fault detection may be more sophisticated than traditional overcurrent protection. To successfully calculate arc flash incident energy levels in AC microgrid systems, the microgrid protection scheme must be thoroughly reviewed and understood.

C. Calculating Incident Energy Levels for AC Microgrid Equipment

Multiple sources of fault current in a microgrid can be considered in an arc flash calculation by doing a piecewise integration. For example, consider a grid-tied microgrid with two operating DERs. Fault current contributed by each source and the clearing time of the source's protection is shown in Table I. This can be re-arranged and calculated using the selected calculation method as shown Table II. The total arc flash incident energy level can be calculated by summing the incident energy level calculated in each period based on the current and time parameters.

TABLE I: EXAMPLE ARCING FAULT CONTRIBUTIONS AND CLEARING TIMES

Source	Fault Current Level	Clearing Time
Bulk System	$I_{Bulk} = 4,000 A$	$t_{c,bulk} = 0.2 s$
DER 1	$I_{DER1} = 500 A$	$t_{c,DER1} = 0.5 s$
DER 2	$I_{DER2} = 80 A$	$t_{c,DER2} = 0.9 s$

TABLE II: EXAMPLE ARCING FAULT CALCULATION PARAMETERS

Time Period	Fault Current Level	Clearing Time
1	$I_{Bulk} + I_{DER1} + I_{DER2} = 4,580 A$	$t_{c,bulk} = 0.2 s$
2	$I_{DER1} + I_{DER2} = 580 A$	$t_{c,DER1} - t_{c,bulk} = 0.3 s$
3	$I_{DER2} = 80 A$	$t_{c,DER2} - t_{c,DER1} = 0.4 s$

This method can be generalized for n fault current sources, assuming constant current throughout the fault, with I_n representing the fault current from source n , $t_{c,n}$ as the clearing time of source n , and $IE(I_n, t_{c,n})$ representing the incident energy calculated as a function of I_n and $t_{c,n}$. The sources are sorted in order of clearing time, such that $t_{c,1} < t_{c,2} < \dots < t_{c,n}$.

$$Total\ IE = IE\left(\sum_{s=1}^n I_s, t_1\right) + IE\left(\sum_{s=2}^n I_s, t_2 - t_1\right) + \dots + IE(I_n, t_{c,n} - t_{c,n-1}) \quad (1)$$

If an individual fault current source changes current output significantly during the event, it can be considered as several sources using (1). For example, if a source initially contributes a fault current $I_{DER,t1}$ and reduces to $I_{DER,t2}$ at time t_x , it can be considered as two sources: one with fault current contribution of $I_{DER,t2}$, cleared at the total fault clearing time, and another with fault current contribution of $I_{DER,t1} - I_{DER,t2}$, cleared at the minimum of the fault clearing time t_x . Common commercial software tools may require supplementary calculations to properly calculate microgrid arc flash incident energy levels as described.

IV. CONCLUSIONS

A microgrid has groups of interconnected loads and DERs and may operate in both grid-connected or island modes. Many aspects of microgrids present challenges for arc flash incident energy calculation.

Microgrids can include DC systems such as BESS, control power and PV as well as low and medium voltage AC systems. Both DC and AC components should be analyzed to determine the incident energy throughout the system. The DC and AC systems included in microgrids require special considerations to calculate expected arc flash incident energy levels.

DC systems require the use of different calculation methods to determine the available incident energy depending on what type of resource is present. Battery resources have a linear relationship between current output and voltage (operating as a Thevenin equivalent source), while PV resources are non-linear and acts as voltage-dependent current sources.

Various fault current scenarios should be considered, including when the system is grid-connected and running in islanded mode with different DERs dispatched, as well as the effect of multidirectional current flow during the arcing fault. Incident energy calculations of AC microgrid systems must account for different types of DERs producing low levels of fault current for various durations of time. A novel piecewise integration approach for calculating the arc flash incident energy levels from several AC sources or source with time-varying fault current contributions during an event has been presented in this article.

ACKNOWLEDGEMENT

The authors gratefully acknowledge the assistance of Fareed Kandlawala - Assistant Manager at S&C Electric Company in reviewing this paper.

REFERENCES

- [1] NFPA 70E, Standard for Electrical Safety in the Workplace, 2018.
- [2] United States Department of Energy, Office of Electricity Delivery and Energy Reliability, Smart Grid R&D Program, "Summary Report: 2012 DOE Microgrid Workshop," July 2012. [Online]. Available: <https://www.energy.gov/sites/prod/files/2012%20Microgrid%20Workshop%20Report%2009102012.pdf>. [Accessed 26 July 2019].
- [3] IEEE Std 1584-2018, IEEE Guide for Performing Arc-Flash Hazard Calculations, 2018.
- [4] F. R. Ammerman, T. Gammon, P. K. Sen and J. P. Nelson, "DC arc models and incident energy calculations," in Petroleum and Chemical Industry Conference, 2009.
- [5] D. R. Doan, "Arc Flash Calculations for Exposures to DC Systems," IEEE Transactions on Industrial Applications, vol. 46, no. 6, pp. 2299-2302, 2010.
- [6] NFPA 70E, Standard for Electrical Safety in the Workplace, 2015.
- [7] P. E. P. W. Michael D. Fontaine, "DC arc flash calculations — Arc-in-open-air & arc-in-a-box — Using a simplified approach (Multiplication factor method)," in Electrical Safety Workshop (ESW), 2012.
- [8] K. D. Carr, "Clearing Time Considerations for DC Arc Flash Hazard Analysis of Battery Banks," in Electrical Safety Workshop (ESW), 2018-25.
- [9] E. H. Enrique, P. N. Haub and T. P. Bailey, "DC Arc Flash Calculations for Solar Farms," in Technologies for Sustainability - Engineering and the Environment (SusTech) Conference, 2013.
- [10] W. R. Sekulic and P. McNutt, "Evaluating the Incident Energy of Arcs in Photovoltaic DC Systems: Comparison Between Calculated and Experimental Data," in Electrical Safety Workshop (ESW), 2019-25.
- [11] Occupational Safety and Health Administration (OSHA), "1910.269 App E - Protection From Flames and Electric Arcs," [Online]. Available: <https://www.osha.gov/laws-regs/regulations/standard-number/1910/1910.269AppE>. [Accessed 1 July 2019].
- [12] R. H. Lee, "The other electrical hazard: Electric arc blast burns," IEEE Trans. Ind. Appl, pp. 246-251, May/June 1982.
- [13] A. Marroquin, A. Rehman and A. Madani, "High Voltage Arc Flash Assessment and Applications," in Electrical Safety Workshop (ESW), 2019-38.
- [14] M. A. Haj-ahmed, M. S. Illindala, "The Influence of Inverter-Based DGs and Their Controllers on Distribution Network Protection," IEEE Trans. on Industry Applications, vol. 50, no. 4, pp. 2928-2937, 2014.